



Procyon g2000

Procyon g2000

Procyon g1600

2 kW High Power, Diode Pumped, Short Pulse Laser

Procyon is a scalable high power laser platform consisting of multiple, synchronised laser modules optimised for stability and reliability. The Procyon g2000 system incorporates ten 200 W green lasers with a centralised control interface for simple operation and easy integration. Modular design and long-life pump diodes ensure high uptime and dependable operation in a 24/7 production environment.



Features

- Pulse Energy up to 10 x 20 mJ
- $M^2 < 30$
- Very Low Jitter
- Excellent Energy Stability
- Excellent Long Term Power Stability
- Condition Monitoring
- Optional Fibre Delivery
- Optional Repetition Frequency Optimization
- Optional Real-time Laser Pulse Diagnostics

Applications

- Poly-Silicon Annealing
- Laser Lift-Off

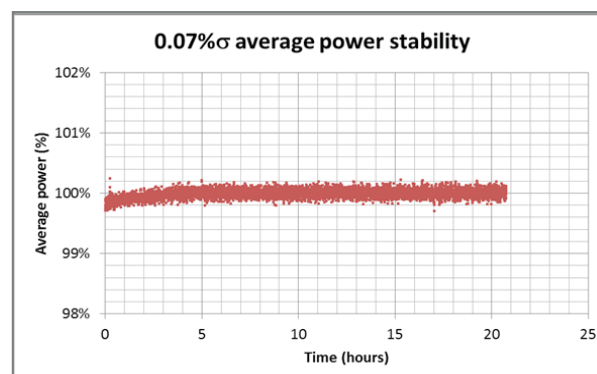



Typical Laser Performance

Pulse Repetition Freq. (kHz)	10
Average Power (W)	10 x 200
Pulse Energy (mJ)	10 x 20
Divergence (mrad, 1/e ² FA)	<4
M ²	<30
Power Stability (% , 1σ)	<0.1
Polarisation	Linear
Fibre Delivery	Optional

Procyon g2000

Procyon g1600

Facility Requirements

Supply Voltage	3-phase N+E, 220 or 400 VAC (±10%)
Supply Frequency	50 or 60 Hz
Nominal Power Consumption	77 kVA
Cooling Water	175 litres/min at 11 - 17°C
Gas Purge	N2 or Air (Grade N5.0, <1 ppm THC)
Laser Dimensions	2200 x 2950 x 1750 mm (h w d)
Control Rack Dimensions	2200 x 1200 x 1750 mm (h w d)
Environmental Conditions	Temp 15 - 32°C and RH <60% (90% max, non condensing)

Specifications subject to change without notice.

Dimensions

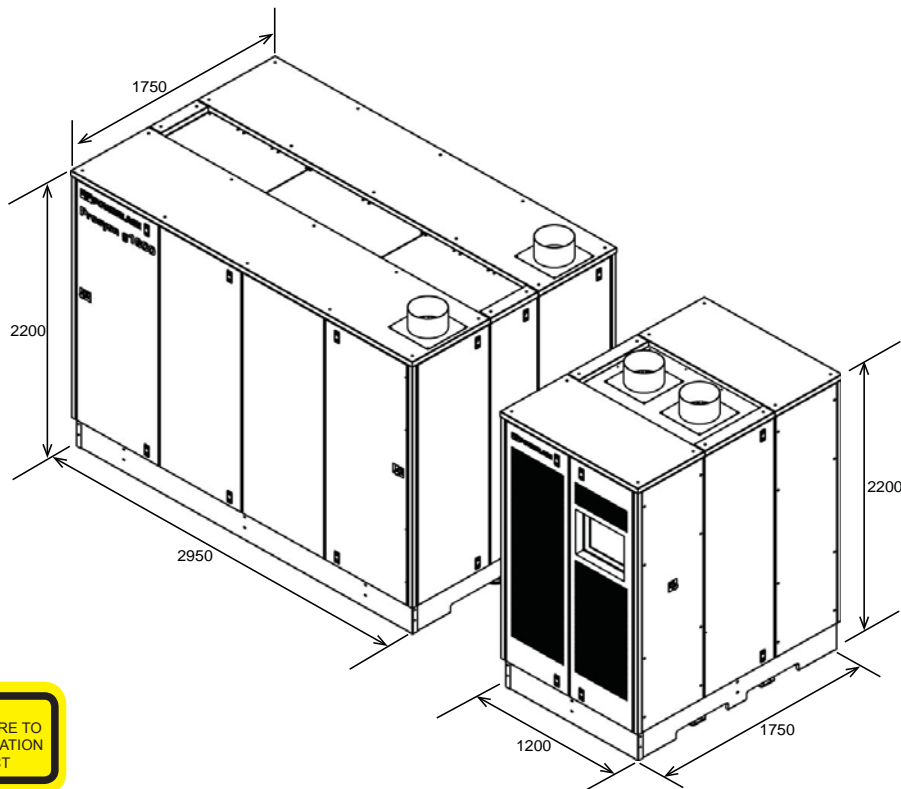

ANDRITZ Powerlase may make improvements and/or changes in the products described herein at any time without notice.

LASER RADIATION
AVOID EYE OR SKIN EXPOSURE TO
DIRECT OR SCATTERED RADIATION
CLASS 4 LASER PRODUCT

Doc No: 069-0064-2